

# GS+

## GAS-FIRED AIR HEATER



## Environmentally friendly heating with the GS+

Mark manufactures a gas-fired, high-performance air heater with an axial fan. This condensing equipment provides efficiency greater than 106% (lower value). Heat is generated via a modulating premix-burner which results in very low gas consumption.

The GS+ is operated using an Optitherm+ clock thermostat or an Interface+ module that allows a connection with the BMS (building management system) via Modbus or a 0-10V contact.



The Optitherm+ also makes it possible to control the GS+ units remotely with an app for mobile phone and tablet (available soon).

The GS+ is suitable in many situations due to its extensive capacity range from 13,6 to 142,2 kW.

The GS+ is designed to heat garages, warehouses, distribution centres and showrooms.

Features of the Mark GS+

- Efficiency >106%
- Energy-saving
- Environmentally-friendly
- Modulating premix burner
- Outlet temperature sensor
- Low temperature rise of the exit air
- Low thermal stratification of the heated air
- Stainless steel heat exchanger
- Corrosion-resistant aluzinc housing

Standard equipment

- Stainless steel combustion chamber & heat exchanger
- Closed combustion circuit
- Advanced modulating burner technology
- Electronic ignition
- Low NO<sub>x</sub>
- Powerful axial fan(s)
- Downflow hood with horizontal louvres
- CE-approval
- PIN 0063BP3341
- Carbon trust (UK)

Optional: speed controlled low noise EC-motor. Advantages:

- The highest efficiency in case of speed control
- Up to 50% energy saving in case of partial load
- Almost completely linearly adjustable
- Long lifetime
- Low noise level
- Integrated electronic thermal protection

# mark®

# Dimensions

- A = Horizontal louvres
- B = Gas connection
- C = Combustion air inlet
- D = Flue gas exhaust
- E = Electrical connection
- F = Axial fan
- G = Condensation connection diam. 40 mm

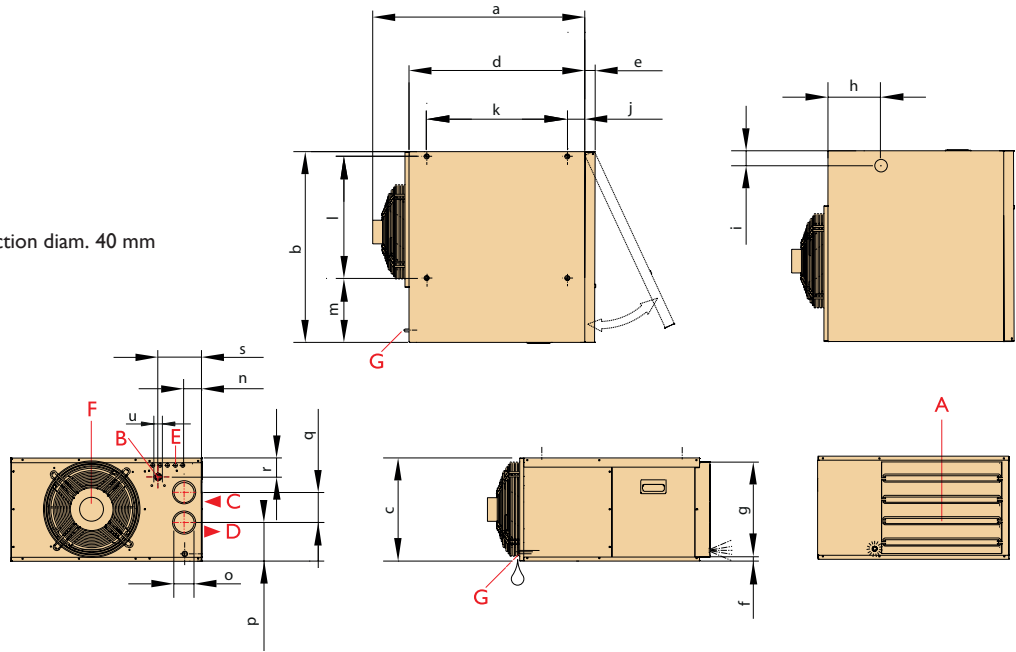

Type	a	b	c	d	e	f	g	h	i	j	k	l	m	n	o	p	q	r	s	u
15/25	790	760	410	700	40	15	380	210	60	70	560	485	255	70	80	150	120	80	175	1/2" (M)

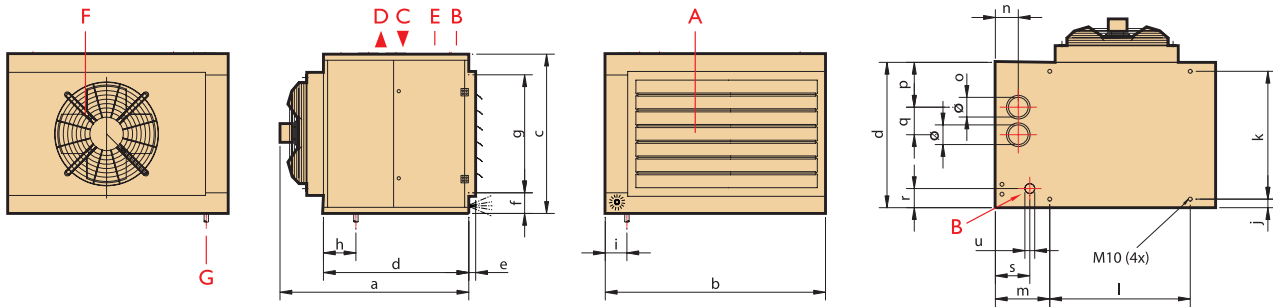

Type	a	b	c	d	e	f	g	h	i	j	k	l	m	n	o	p	q	r	s	u
35	969	875	810	739	35	105	600	165	110	90	560	470	275	120	80	240	120	97	135	3/4" (M)
40	969	875	810	739	35	105	600	165	110	90	560	470	275	120	80	240	120	97	135	3/4" (M)
60	969	1120	810	739	35	105	600	165	110	90	560	715	275	120	100	230	140	97	135	3/4" (M)
80	969	1305	810	739	35	105	600	165	110	90	560	890	275	120	100	230	140	97	135	1" (M)
100	979	1595	810	739	35	105	600	165	110	90	560	1180	275	120	100	230	140	97	135	1" (M)
135/150	1180	1890	1000	1000	35	105	790	190	175	75	850	1455	295	165	130	235	225	140	170	1" (F)

Type		15	25	35	40	60	80	100	135	150
Nominal load (upper value)	kW	16,1	27,2	38,8	44,4	66,7	88,9	110,6	149,9	166,7
Maximal power	kW	13,6	23,0	33,4	38,4	56,2	75,6	93,3	128,9	141,0
Minimal load (upper value)	kW	4,6	6,8	9,6	9,6	13,9	24,5	10,8	21,1	36,6
Minimal power	kW	4,3	6,6	9,2	9,2	13,5	23,8	10,6	20,6	35,3
Flue efficiency at maximum load (lower value) on/off fan	%	94,1	93,9	95,1	95,1	93,6	94,0	93,8	95,5	94,0
Flue efficiency at maximum load (lower value) modulating fan	%	93,2	94,0	94,8	94,8	94,0	94,4	93,9	95,7	94,8
Flue efficiency at minimum load (lower value) on/off fan	%	106,7	107,0	106,9	106,9	107,3	107,1	107,4	107,5	107,3
Flue efficiency at minimum load (lower value) modulating fan	%	106,1	106,7	106,4	106,4	106,6	106,9	106,9	107,4	107,1
Burner turndown ratio	+/-	3:1	4:1	4:1	5:1	5:1	7:1	6:1	7:1	4:1
Gas consumption G20 (15°C)	m <sup>3</sup> /h	1,50 - 0,41	2,54 - 0,57	3,62 - 0,89	4,15 - 0,90	6,22 - 1,07	8,29 - 1,27	10,30 - 1,68	13,99 - 1,76	15,57 - 3,68
Gas consumption G25 (15°C)	m <sup>3</sup> /h	1,75 - 0,49	2,95 - 0,65	4,1 - 1,02	4,73 - 1,02	7,03 - 1,20	9,3 - 1,44	11,57 - 1,91	15,98 - 2,00	17,65 - 4,18
Air displacement (20°C) on/off fan	m <sup>3</sup> /h	1410	2190	5000	5000	5300	9000	9800	16300	16300
Air displacement (20°C) modulating fan	m <sup>3</sup> /h	850 - 1730	1090 - 2470	1350 - 3900	1350 - 3900	2700 - 5500	4500 - 8800	5400 - 9400	7350 - 14500	7350 - 16300
Delta T (ΔT) on/off fan	K	29,0 - 9,2	31,5 - 9,0	20,0 - 5,5	23,1 - 5,5	31,8 - 7,7	25,2 - 7,9	29,6 - 9,2	23,7 - 3,8	25,9 - 6,5
Delta T (ΔT) modulating fan	K	23,4 - 14,8	28,0 - 17,8	25,7 - 20,4	29,3 - 19,9	30,8 - 14,5	25,9 - 15,6	30,9 - 16,5	26,7 - 8,3	26,2 - 14,2
Throw	m	10 - 16	14 - 20	28 - 36	26 - 36	26 - 36	32 - 46	36 - 50	48 - 68	48 - 68
Weight of GS+	kg	50	56	95	95	111	136	155	228	230
Noise level (5 m, side) on/off fan	dB(A)	44	48	48	48	51	52	52	58	58
Noise level (5 m, side) modulating fan	dB(A)	44-31	48-31	47-31	47-31	51-33	49-33	52-34	55-34	55-34
Electrical power at 230V	W	100	175	290	290	340	480	510	1300	1300
Consumed current	A	0,5	0,8	1,4	1,4	1,6	2,3	2,5	5,9	5,9

## Accessories – flue gas exhaust

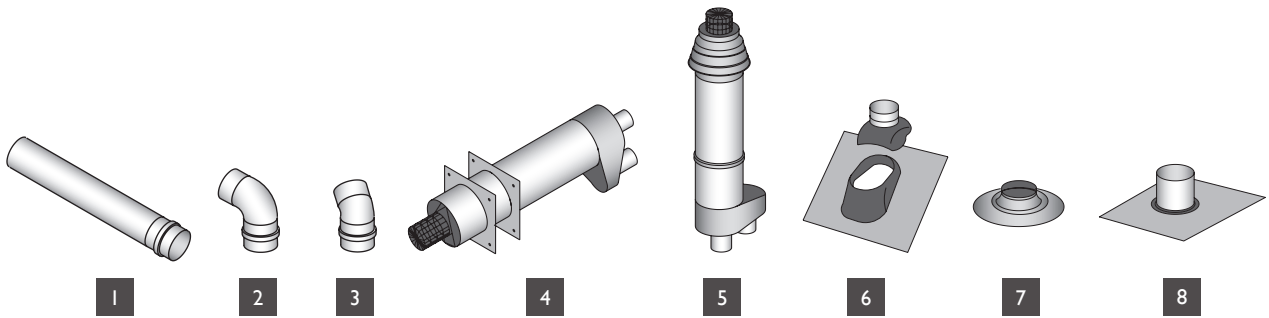

- 1 Extension set
- 2 90° elbow
- 3 45° elbow
- 4 Single flue set horizontal
- 5 Single flue set vertical
- 6 Roof flashing for pitched roof
- 7 Adhesive plate
- 8 Flexible roof flashing for cladded roof

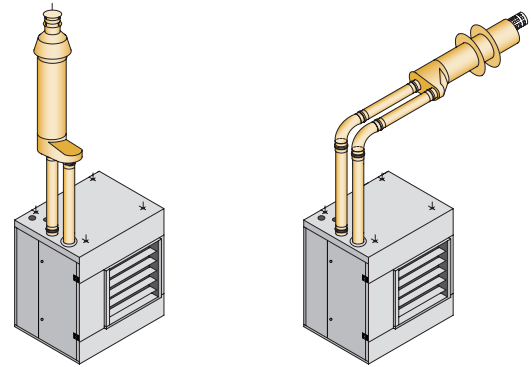

## Accessories – additional sections

- 1 = Horizontal louvers (standard)
- 2 = Vertical louvres
- 3 = Downflow hood 45°
- 4 = Diffuser (2 x 45°) and horizontal louvers
- 5 = Vertical louvres for diffuser
- 6 = Set of wall mounting brackets
- 7 = Shock absorbers set
- 8 = Reversible wall bracket (types 15 - 60)

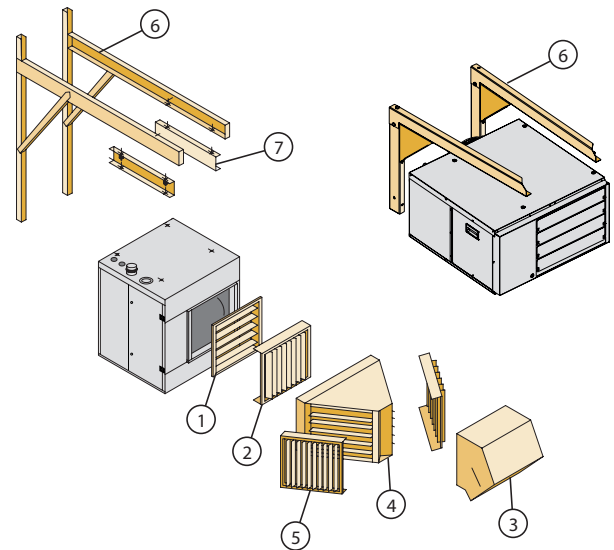

## Assembly/location suggestions

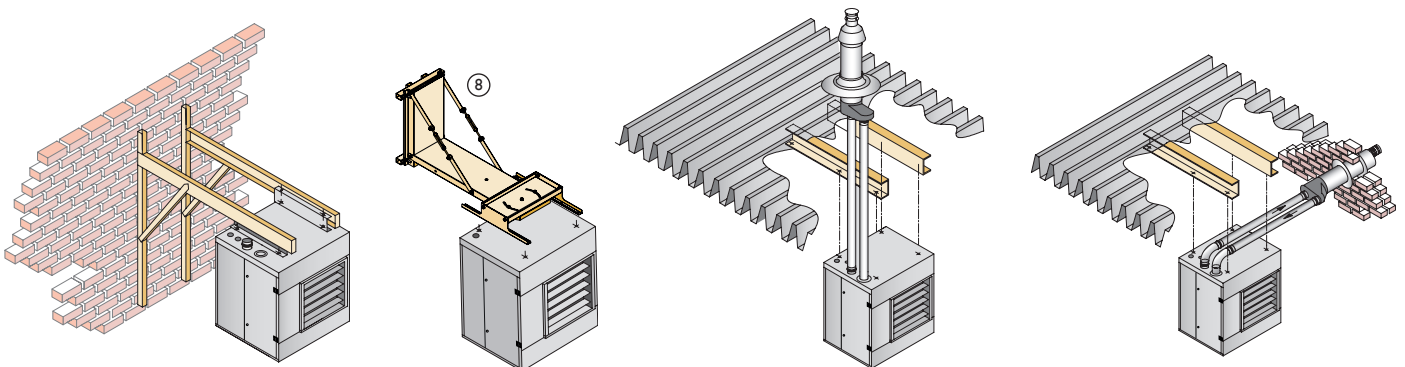

Installation with:

- Optitherm+
- Room temperature control

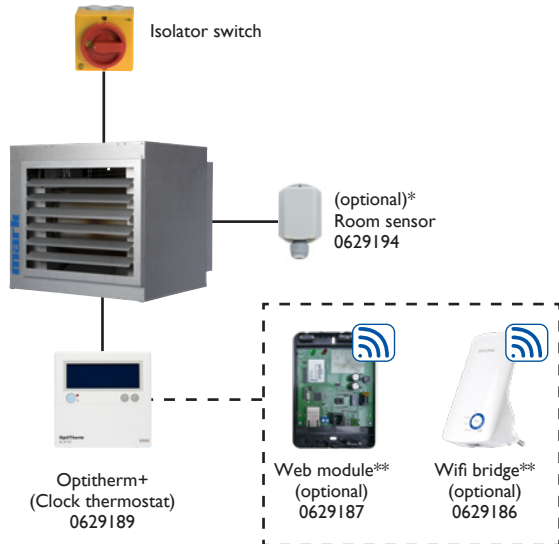

Installation with:

- Interface+
- Capacity control with external 0-10V signal or Modbus.



Installation with:

- Optitherm+ in combination with Interface+
- Room temperature control in combination with Modbus. Allows you to read the status and change the settings of the Optitherm+.

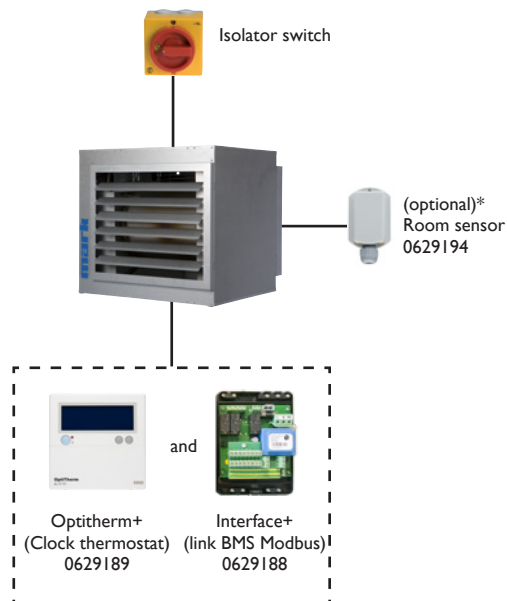

\* Only in combination with Optitherm+

\*\* A remote connection with the mobile phone app is only possible when using a Web module. A WiFi bridge can be added to create a wireless connection (available soon). NOTE: The use of a Web module, possibly in combination with a Wifi bridge, is not possible when using an Interface+.

Installation with:

- Optitherm+
- Room temperature control

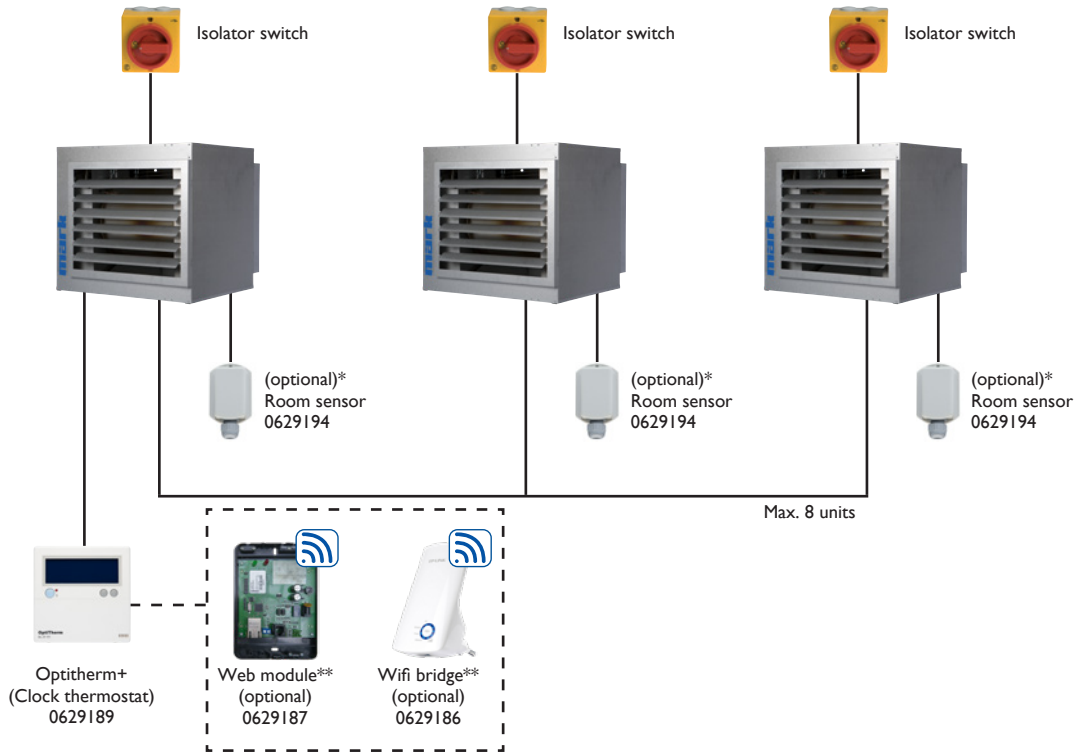

Installation with:

- Optitherm+ in combination with Interface+
- Room temperature control in combination with Modbus. Allows you to read the status and change the settings of the Optitherm+.

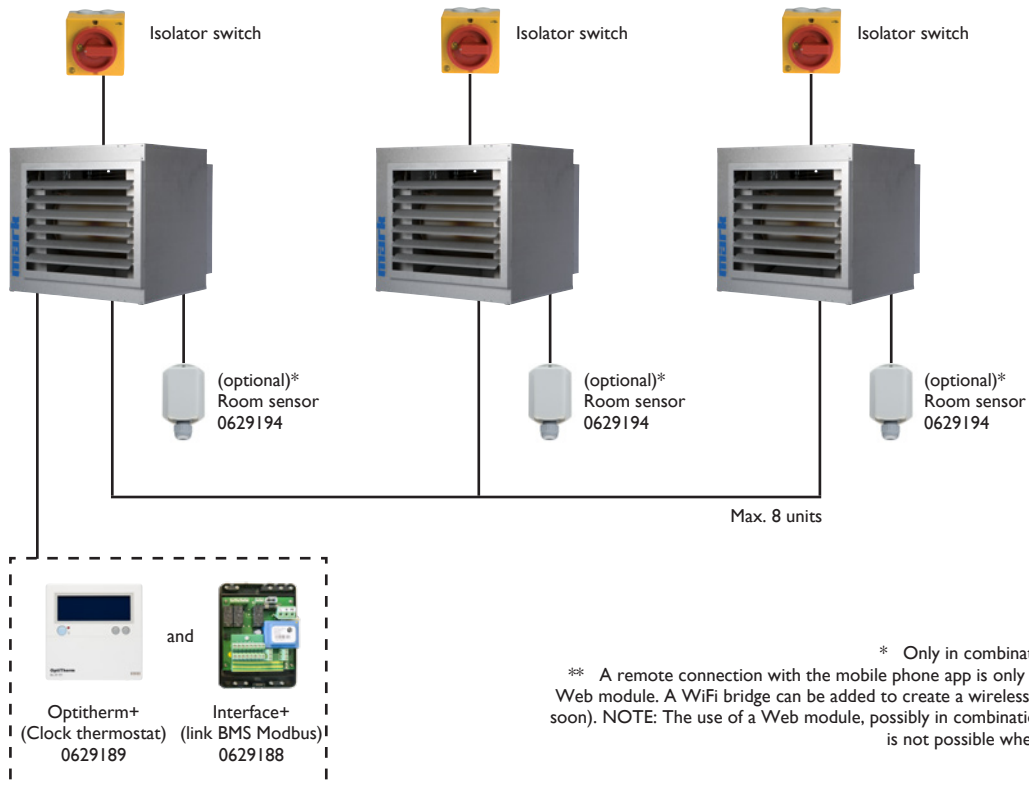

\* Only in combination with Optitherm+

\*\* A remote connection with the mobile phone app is only possible when using a Web module. A WiFi bridge can be added to create a wireless connection (available soon). NOTE: The use of a Web module, possibly in combination with a Wifi bridge, is not possible when using an Interface+.